

**PLANTA HUMANIZADA
SALA ALESSANDRA**
ESC: 1/30
ÁREA: 12,95²



PORTA
ENTRADA

CARVALHO CANELA EUCATEX



BRANCO ICELAND GUARARAPES

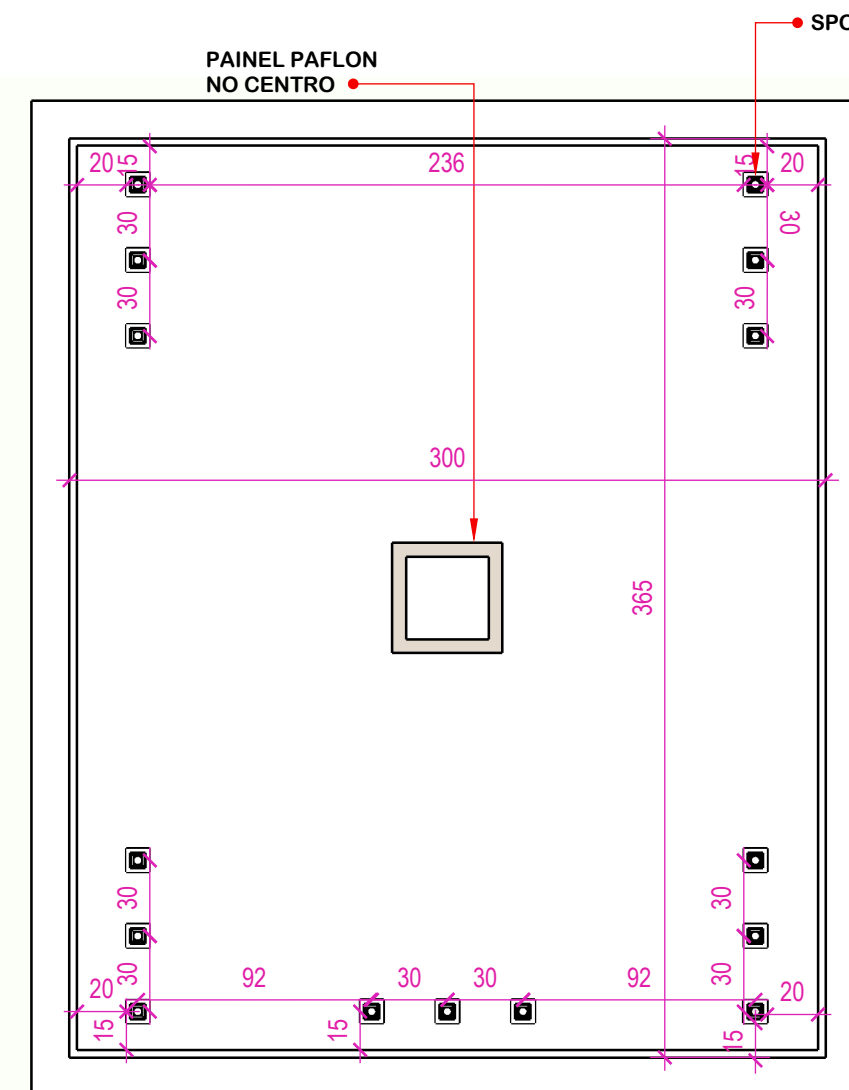
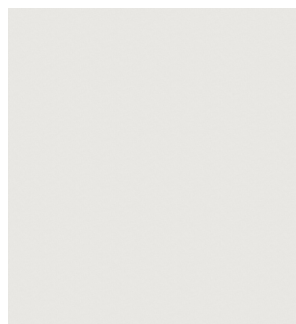

PLANTA ILUMINAÇÃO
ESC: 1/30

1. TODAS AS MEDIDAS DEVERAM SER REVISADAS PELO MARCENEIRO;
2. QUALQUER MUDANÇA NO PROJETO DEVE SER COMUNICADA AO CLIENTE OU ARQUITETA;
3. QUALQUER DUVIDA ENTRAR EM CONTATO PELO TELEFONE NA LEGENDA;
4. CONTRADIÇÕES ENTRE AS COTAS E A ESCALA, A COTA PREVALECERÁ.

CLIENTE	PREFEITURA MUN. DE SÃO CRISTOVÃO DO SUL		<p>ELIANE BORDIN ARQUITETA</p>	<p>ELIANE BORDIN ARQUITETURA & INTERIORES</p> <p>END. RUA PEDRO GRIMES Nº 421- ADOLFO CORREIA DA SILVA SANTA CECÍLIA-SC eliane-bordin@hotmail.com +55 49 98864-3950</p>	<p>01 /05</p>
END. DA OBRA	CENTRO				
ASSUNTO	PLANTAS HUMANIZADA E DETALHES				
ETAPA	DESIGNER DE MÓVEIS				
	ESCALA	INDICADA			
	DATA	22-06-2021			
	AUTOR	ELIANE BORDIN			

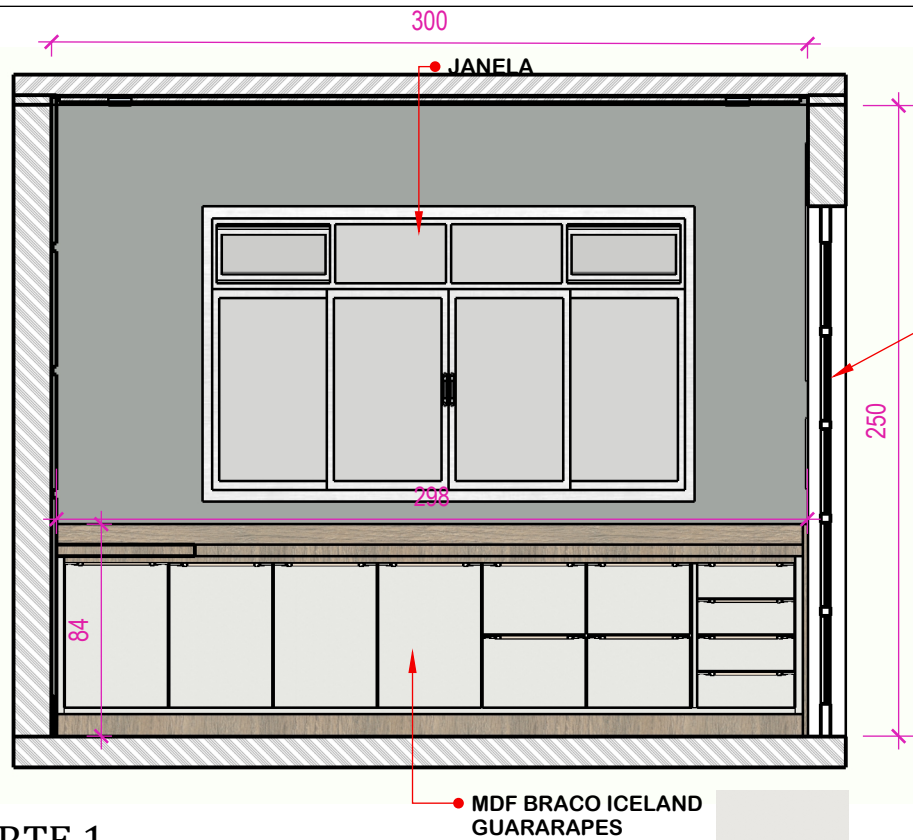

CORTE 1
ESC: 1/30



DETALHE EM MDF
preto silk linha
comfort
guararapes

PORTA
ENTRADA
SALA SECRETÁRIO

MDF BRACO ICELAND
GUARARAPES

MDF CARVALHO CANELA
EUCATEX

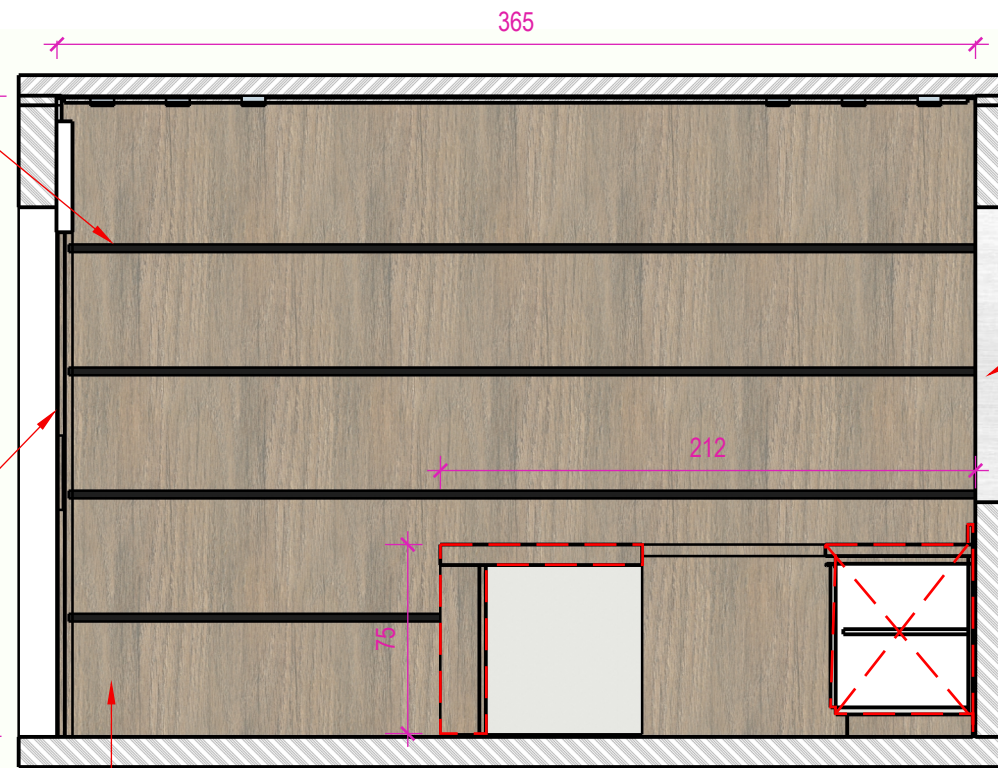

CORTE 2
ESC: 1/30

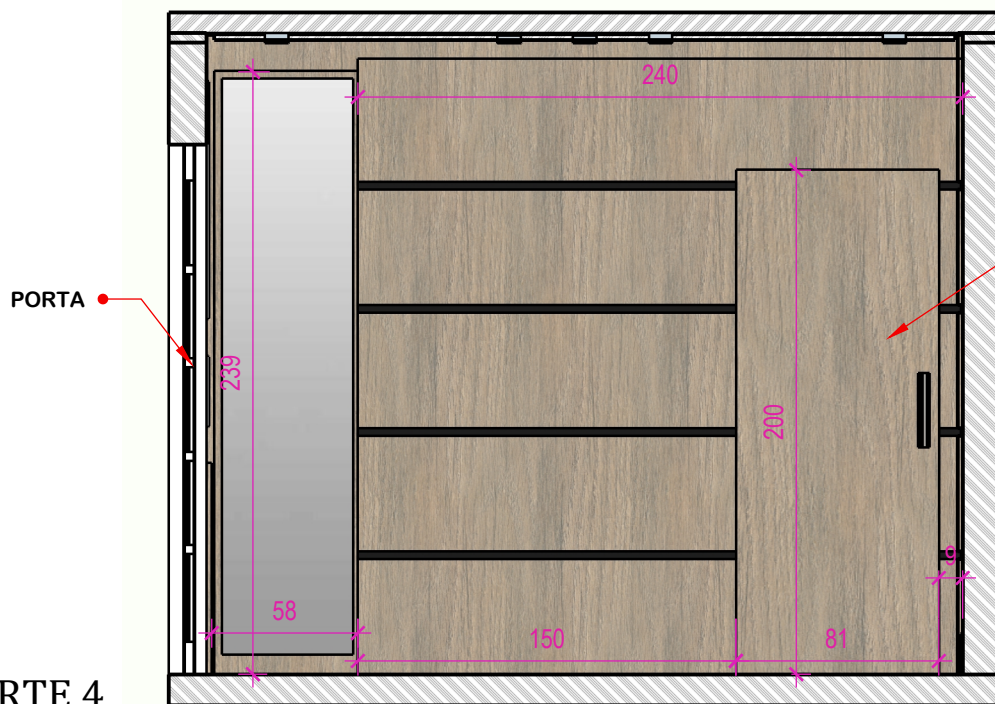

CORTE 4
ESC: 1/30

PORTA
DE CORRER

JANELA

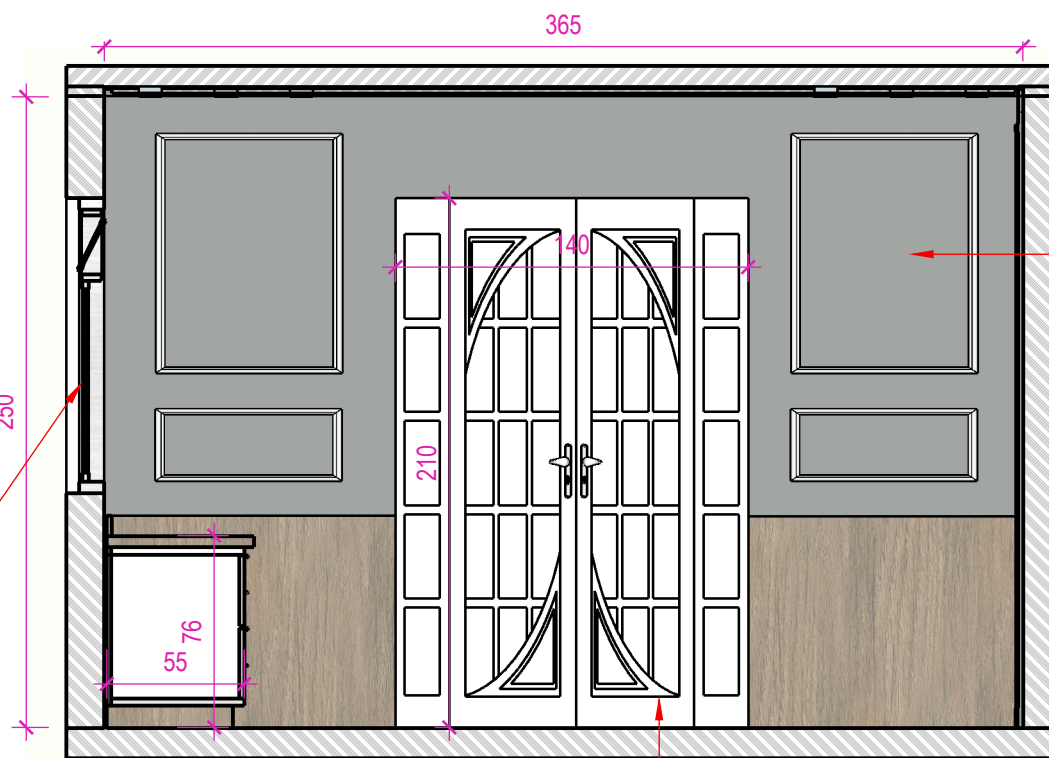

CORTE 3
ESC: 1/30

CINZA
PLATINA SUVINIL

PORTA ENTRADA

CLIENTE PREFEITURA MUN. DE SÃO CRISTOVÃO DO SUL		 <p>ELIANE BORDIN ARQUITETA</p>	ELIANE BORDIN ARQUITETURA & INTERIORES	<p>02 /05</p>
END. DA OBRA CENTRO	ESCALA INDICADA		END. RUA PEDRO GRIMES Nº 421- ADOLFO CORREIA DA SILVA SANTA CECÍLIA-SC eliane-bordin@hotmail.com +55 49 98864-3950	
ASSUNTO CORTES	DATA 22-06-2021			
ETAPA DESIGNER DE MÓVEIS	AUTOR ELIANE BORDIN			

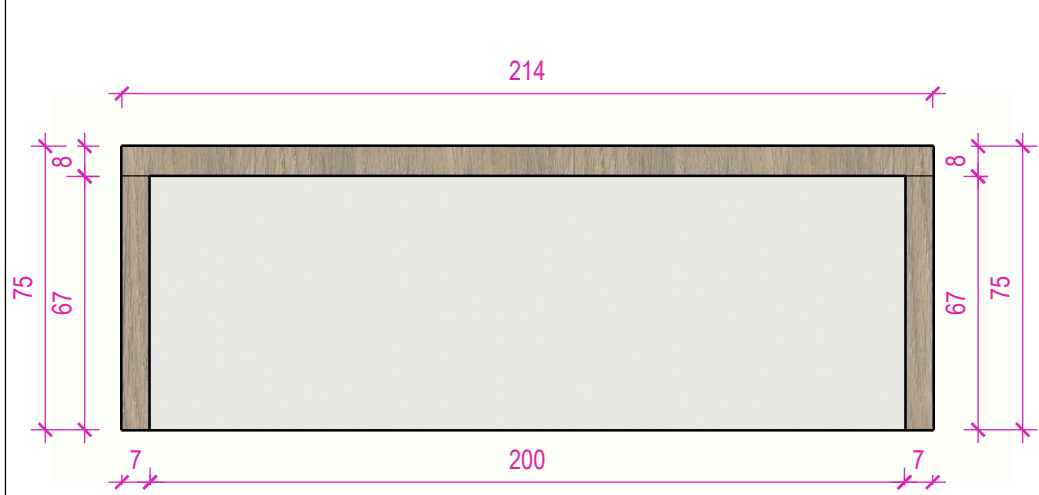

MESA FRONTAL
ESC: 1/20

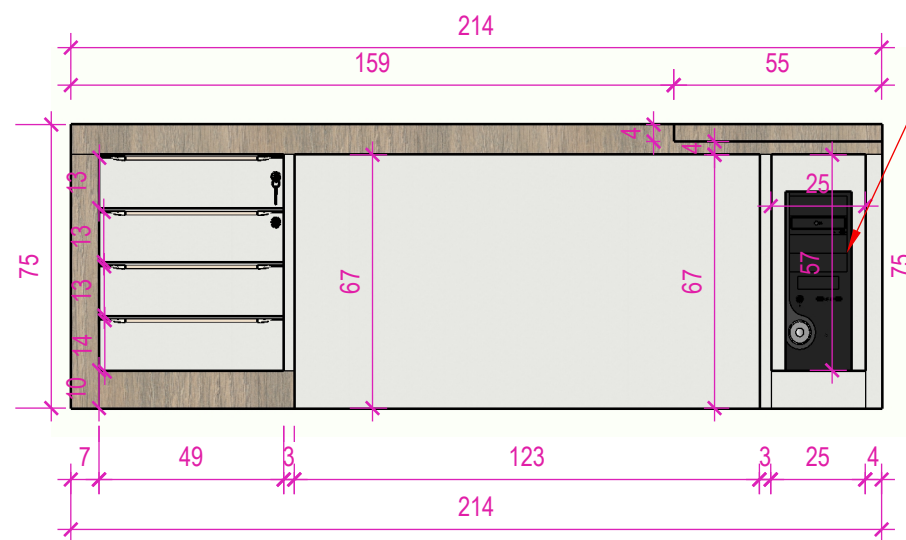

MESA INTERNA
ESC: 1/20

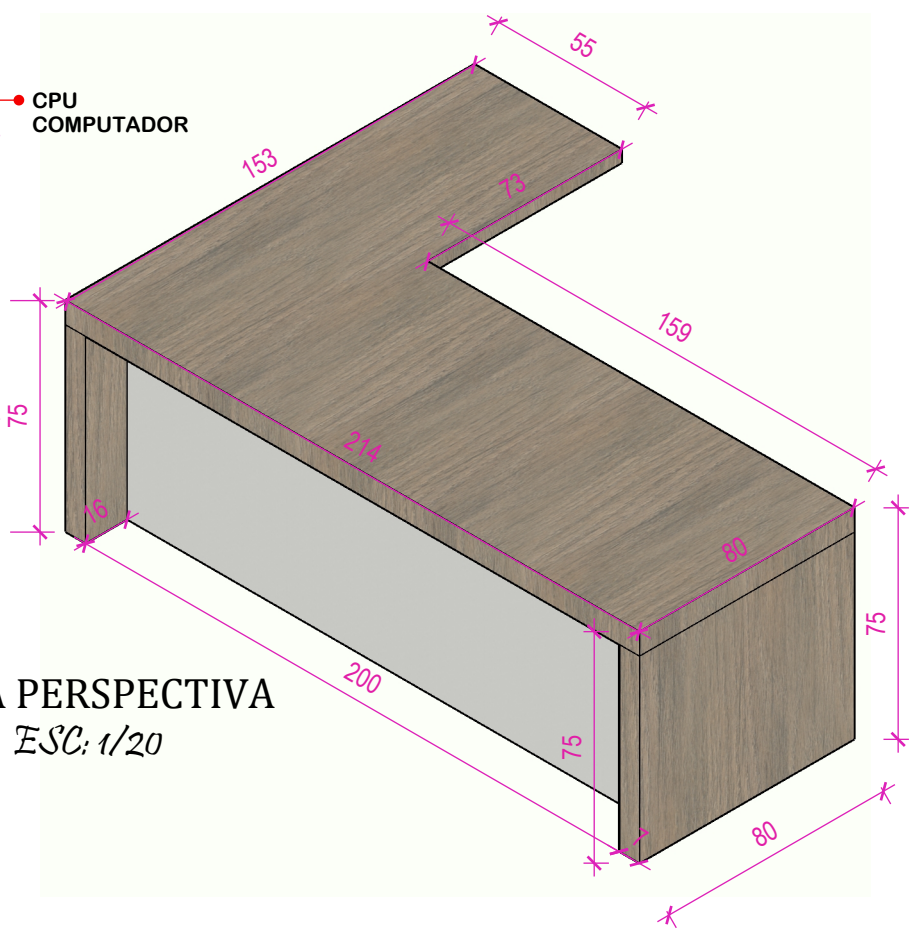

MESA PERSPECTIVA
ESC: 1/20

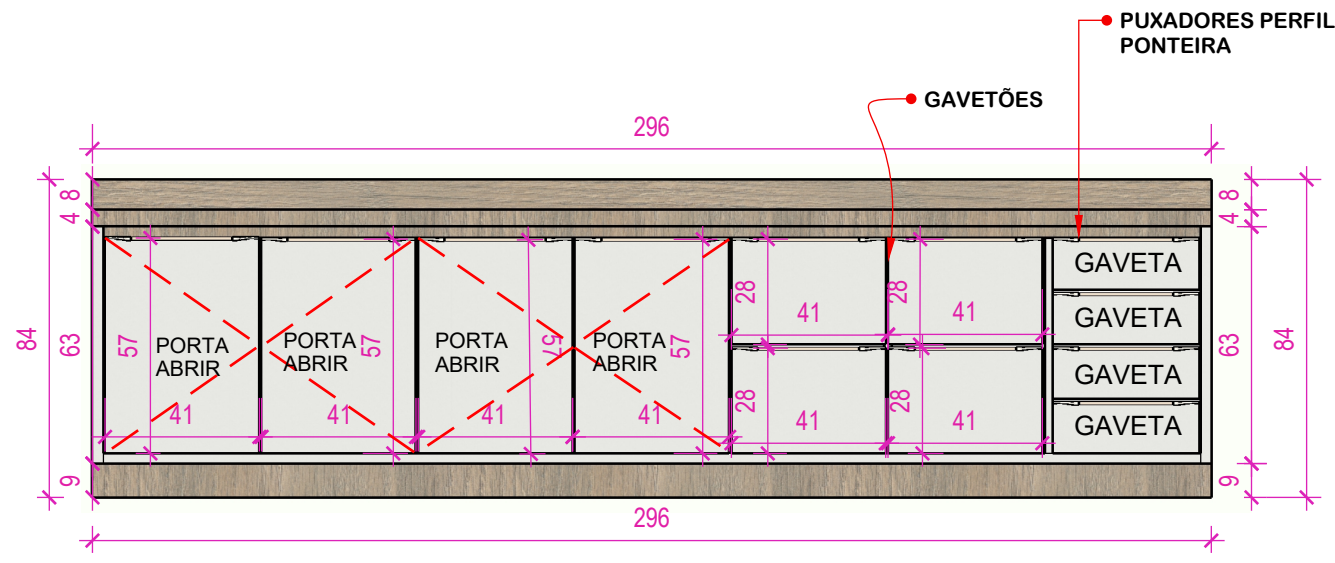

BALCÃO
ESC: 1/20

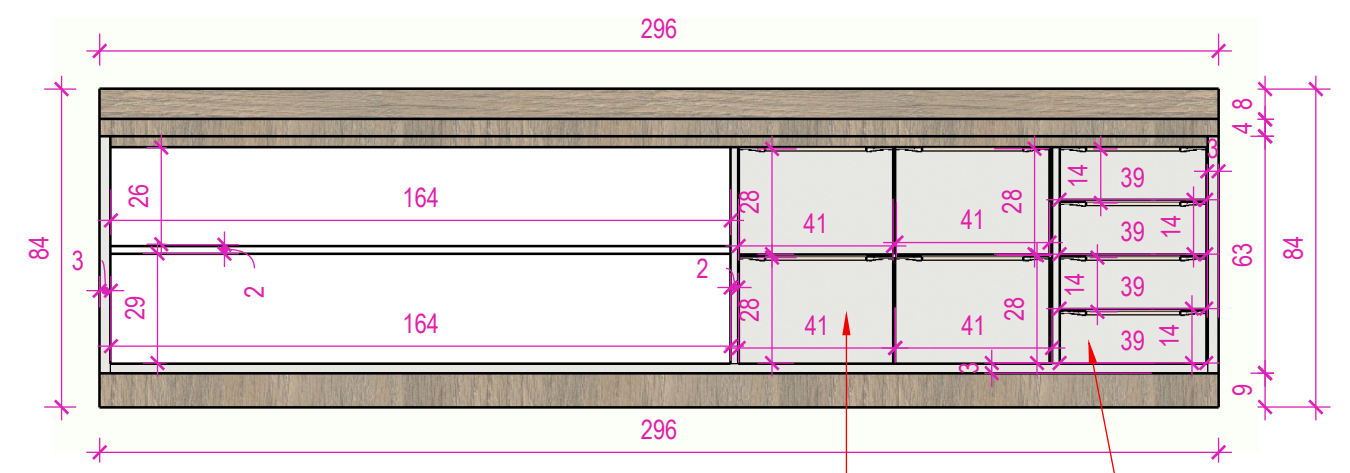

BALCÃO-INTERNO
ESC: 1/20

CLIENTE	PREFEITURA MUN. DE SÃO CRISTOVÃO DO SUL	
END. DA OBRA	CENTRO	ESCALA INDICADA
ASSUNTO	MESA-BALCÃO	DATA 22-06-2021
ETAPA	DESIGNER DE MÓVEIS	AUTOR ELIANE BORDIN



ELIANE BORDIN
ARQUITETURA &
INTERIORES
END. RUA PEDRO GRIMES Nº 421- ADOLFO
CORREIA DA SILVA
SANTA CECÍLIA-SC
eliane-bordin@hotmail.com
+55 49 98864-3950

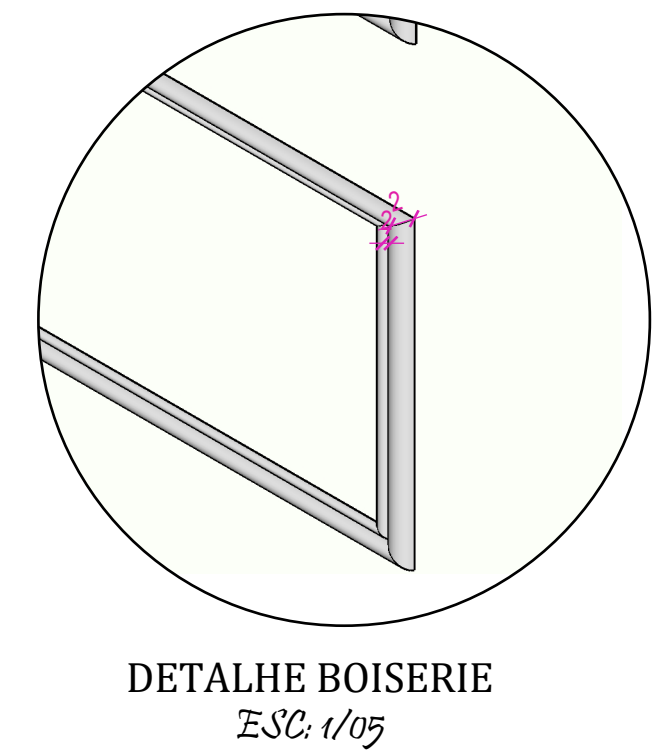
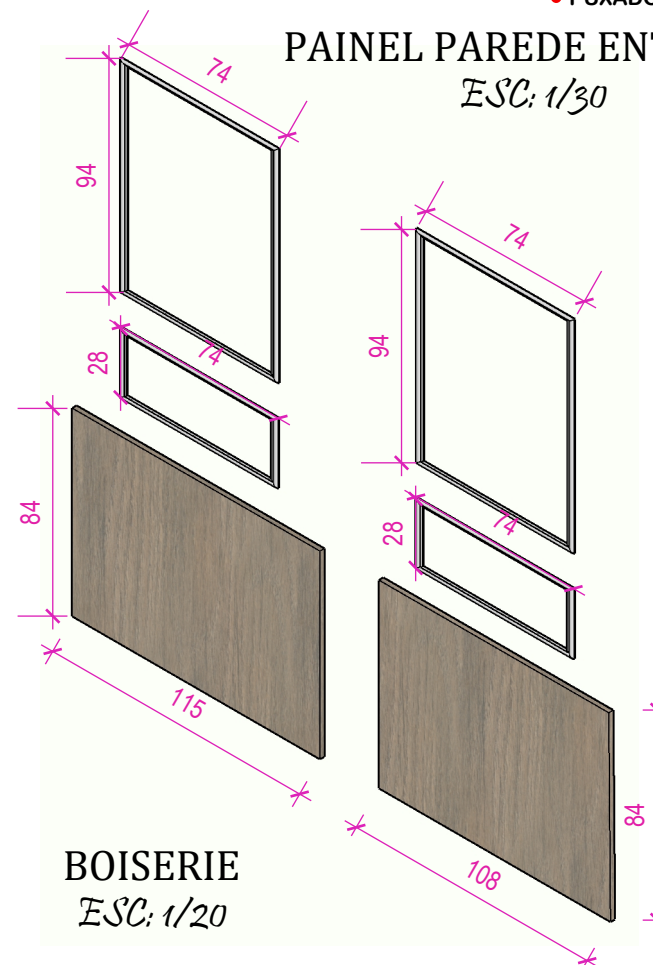
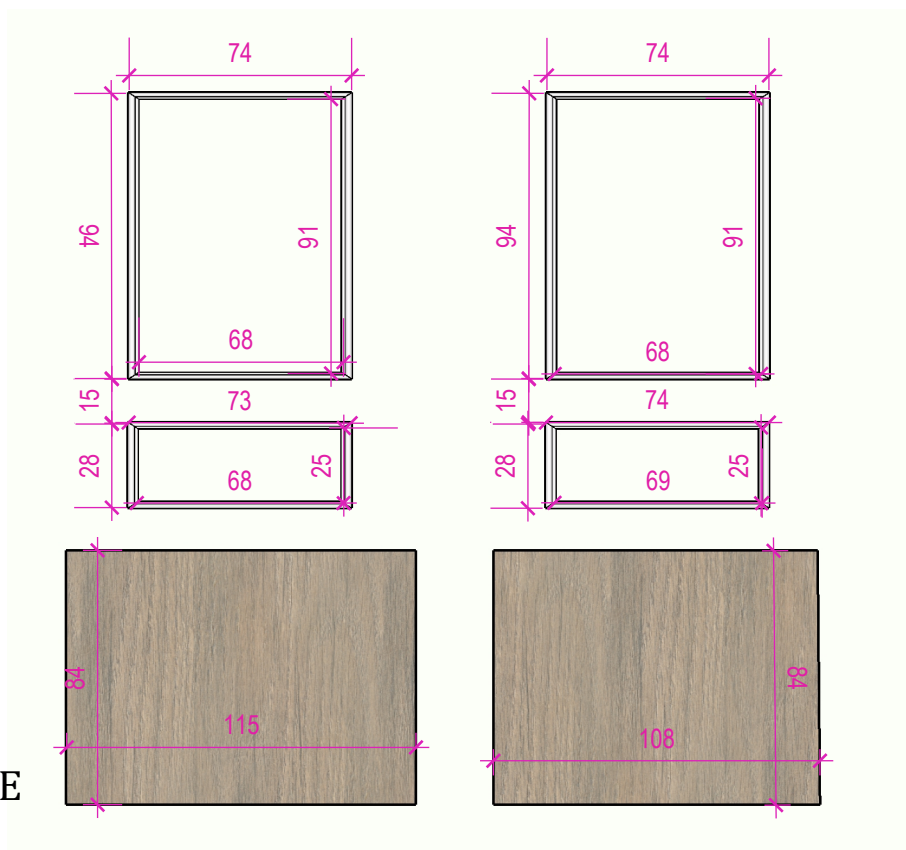
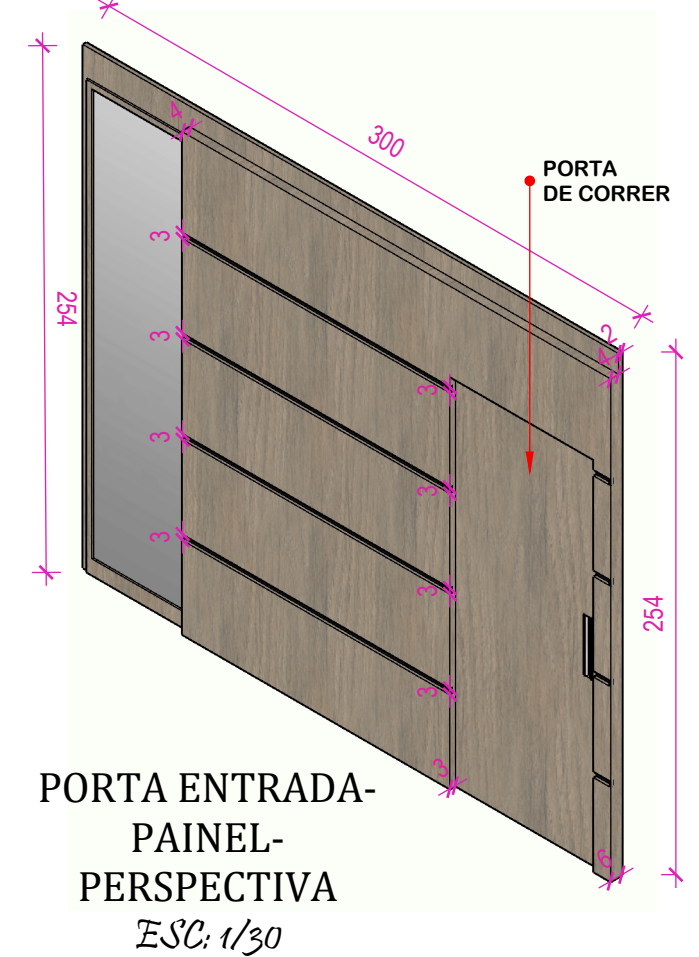
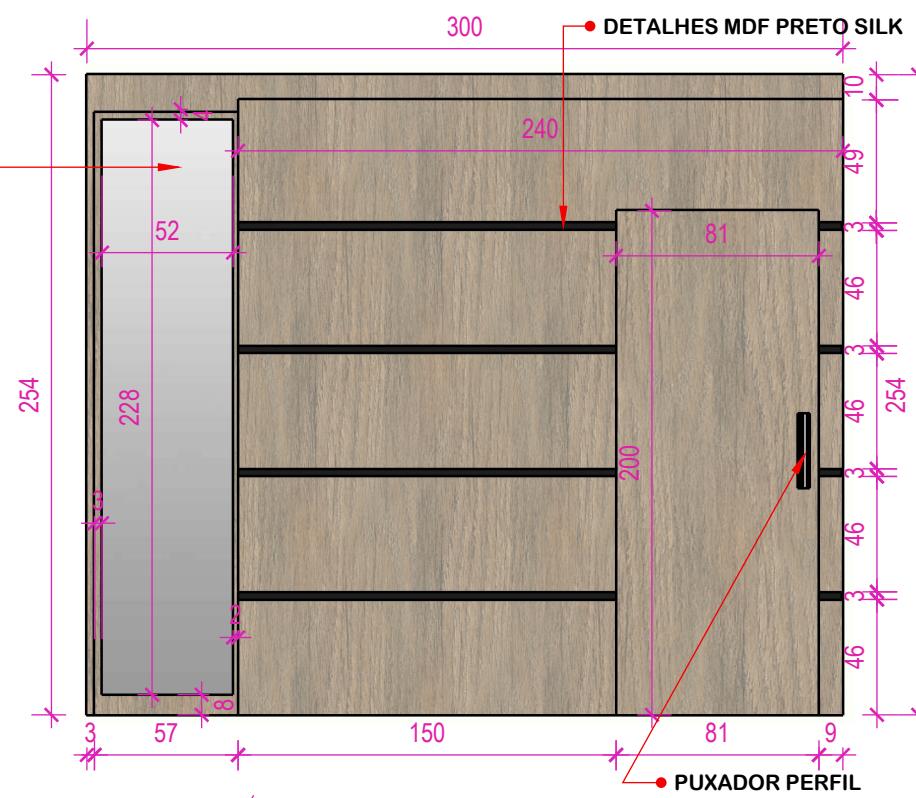
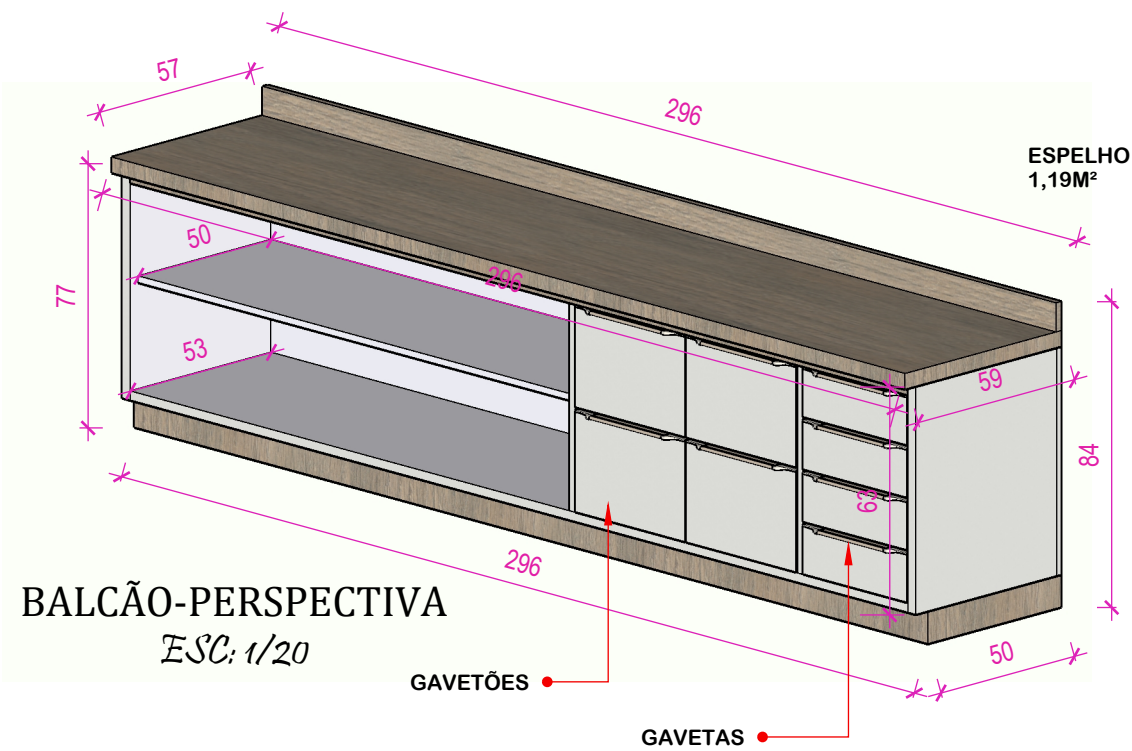

CLIENTE	PREFEITURA MUN. DE SÃO CRISTOVÃO DO SUL	
END. DA OBRA	CENTRO	ESCALA
ASSUNTO	BALCÃO-BOISERIE	INDICADA
ETAPA	DESIGNER DE MÓVEIS	DATA
		22-06-2021
		AUTOR
		ELIANE BORDIN



ELIANE BORDIN
ARQUITETURA &
INTERIORES

END. RUA PEDRO GRIMES Nº 421- ADOLFO
CORREIA DA SILVA
SANTA CECÍLIA-SC
eliane-bordin@hotmail.com
+55 49 98864-3950

FOTOS

TINTA CINZA PLATINAS
SUVINIL



INDICAÇÃO : PORTA EXISTENTE PINTAR EM TINTA BRANCA



CLIENTE	PREFEITURA MUN. DE SÃO CRISTOVÃO DO SUL	
END. DA OBRA	CENTRO	ESCALA INDICADA
ASSUNTO	FOTOS	DATA 22-06-2021
ETAPA	DESIGNER DE MÓVEIS	AUTOR ELIANE BORDIN



ELIANE BORDIN
ARQUITETURA &
INTERIORES
END. RUA PEDRO GRIMES Nº 421- ADOLFO
CORREIA DA SILVA
SANTA CECÍLIA-SC
eliane-bordin@hotmail.com
+55 49 98864-3950

05
/05